

quatreau™

ONE TAP FOUR FUNCTIONS: PURE BOILING - PURE CHILLED - PURE SPARKLING - THERMOSTATICALLY CONTROLLED TAP WATER





PUREINNOVATION

Style

Elegance and purity combine to bring you **Quatreau™**, the world's first touch sensitive tap designed for today's lifestyle.

When we launched **Quatreau™** in 2009 it was the first tap ever to dispense both tap water and pure water with boiling, chilled and sparkling options. Today it remains the only tap to deliver these functions and in our customers' views is the most stylish and fantastic tap on the market.

Quatreau™ also delivers hot and cold unfiltered tap water with thermostatic control for the perfect temperature and flow first time.

A new focal point, a tap that excites, designed and manufactured in Great Britain, **Quatreau™** represents the evolution of tap design bringing water purity and function to the centre stage in your kitchen.

Follow our new designs as they are launched at quatreau.com

Quatreau is now made from solid 316 stainless steel avoiding environmental impact of plating.

Function

Building on our 21 years' experience we are proud to announce the launch of **Hydrocell®**, the first subsink control unit producing chilled, carbonated and boiling water with thermostatic control for mains hot and cold water.

Hydrocell® comes with a choice of built-in filtration modules to suit local water problems.

Hydrocell® integrates a carbon dioxide module making replacement an easy task.

One of the main problems with water chillers is the extraction of heat that normally requires unsightly vents to prevent heat damage. **Hydrocell®** is designed to vent directly into the kickspace which not only makes use of wasted space but removes the problem of heat extraction.

More innovation and world firsts from the makers of **Quatreau™**.

Purity

Upgrading to our patented RODI system delivers water purity and taste that is second to none, in fact it is purer than every bottled water brand.

Still or sparkling, you'll be amazed just how clean and pure RODI water tastes. It also makes the most incredible difference to tea, creating a beautiful amber infusion with no oily scum on the surface. Coffee is fuller flavoured with the perfect Arabica crema. It is no surprise therefore Raymond Blanc chooses our systems at Le Manoir aux Quat'Saisons.

Scale has always posed a major problem for devices that use water. Whilst filtration can reduce the effects of scale, RODI is the only purifier that removes all impurities including scale. Consequently with RODI we can guarantee all our appliances will be free from scale damage.

We believe that RODI water is the healthiest drink on the planet delivering well-being and taste.

Quatreau is now made from solid 316 stainless steel avoiding the environmental impact caused by plating

the upper left quadrant delivers boiling PureH2O



INSTANTBOILING

- Tea
- Coffee
- Pasta
- Blanching
- Sterilising
- Baby formula
- Pre-heating
- Poaching
- Vegetable preparation
- Steaming

Upgrading to our patented RODI system makes the most incredible difference to tea, creating a beautiful amber infusion with no oily scum on the surface. Why not try with some fresh mint from the garden. Coffee brews with a fuller flavour and the perfect Arabica crema.

With RODI water you couldn't choose a safer option for baby formula.

Safe handling

The boiling safety function requires a three step touch sequence to activate. Auto cut-off after 60 seconds. Outer hoop of the tap remains cool to touch to prevent scalding.

The perfect temperature

Tea and coffee are best prepared using water that's just come off the boil between 92-96°C. Quatreau™ delivers at the ideal temperature of approximately 96°C thereby avoiding the spitting and spluttering associated with higher temperatures.

Did you know that hot beverages cannot be comfortably drunk until the temperature drops to 70°C.

So boiling water to 100°C every time you make a tea or coffee is a waste of valuable energy resources.



the upper right quadrant delivers chilled PureH2O



INSTANTCHILLED

Nothing is more refreshing on a warm summer's day than beautifully chilled filtered or pure RODI water. Serve in a glass jug with slices of citrus fruit and mint for the ideal accompaniment to your al fresco dining. Add a small splash of your favourite cordial for a subtly flavoured alternative.

Pastry, bread or pizza dough mixes benefit from the chilled factor. Use straight from the tap to rinse fruit and vegetables prior to preparation to thoroughly remove any residues. Prepare salads and give them a final toss in chilled water to refresh prior to serving.

Halt the cooking process. For the perfect pasta cook using the boiling function, strain and rinse under the chilled flow briefly to arrest further cooking and finally reheat under the boiling stream. For chilled shellfish or vegetables, boil for the appropriate time and plunge into a bowl of chilled water to avoid overcooking.

Upgrading to our patented RODI system eliminates the need to buy bottled water and its associated environmental impact.

Use PureH2O for crystal clear ice and don't forget RODI water gives a spot free rinse to glassware and is a great way of chilling glasses.



the lower right quadrant delivers sparkling PureH2O



INSTANT SPARKLING

Never has sparkling water tasted so good. Endless combinations await you and your family. As an alternative to sugar based fizzy drinks let your children create their own favourite using diced fruit and sparkling water.

Blend fruit until smooth, add the same amount of sparkling water and mix for a couple of seconds for an effervescent smoothie. Or why not try a sparkling elderflower jelly by setting your favourite berries or fruit in a jelly made with elderberry cordial and sparkling water.

Need a pick me up? Soak a flannel under the stream of sparkling water until chilled. Gently squeeze and apply to the face or back of the neck for a refreshing alternative tonic.

Upgrading to our patented RODI system eliminates the need to buy bottled sparkling water and its associated environmental impact.

Remember to sip a large glass before reaching for the headache pills – PureH2O is the perfect answer to hydration and is the first step in a good skincare regime.



the lower left quadrant delivers hot and cold tap water

HOT & COLD TAP WATER

Quatreau™ saves water by dispensing mains tap water at the perfect pre-set temperature for rinsing and washing. Simply touch the lower left quadrant once.

The temperature is thermostatically pre-set to 40°C and can be adjusted to suit your preference, delivered in a controlled stream to prevent splashing. No more scalding your hands trying to set the temperature by mixing hot and cold water. A great way of saving water.

For cold tap water double touch the same icon. It is unlikely you will need this option once you've discovered the benefits of PureH2O but if you do find a use let us know.





QUATREAU TAP SYSTEMS

Quatreau™

Quatreau™ combines function and design to bring you the ultimate in kitchen multi-function taps. With our modular approach you can build the system that suits you.

Finishes

The elegant and stylish tap unit with unique touch sensitive control panel is available in solid stainless steel with either a brushed or polished finish.

Our product design team will be pleased to accommodate bespoke finishes to suit individual tastes (subject to extended lead time and cost).

Hydrocell®

Hydrocell® sub-sink system

Our new compact system delivers boiling, chilled and sparkling water functions.

- Thermostatically controlled mains hot and cold as standard
- Incorporates unique innovative kick space venting.
- Enhanced performance and responsiveness.
- Easy to install and maintain with quick fit filters and CO2 cartridges
- All **Hydrocell®** units incorporate multi-media filters to reduce impurities found in mains fed water.

Hydrocell® 500

- ✓ Filtered boiling
- ✓ Filtered chilled
- ✓ Filtered sparkling

Hydrocell® 450

- ✓ Filtered boiling
- ✓ Filtered chilled

Hydrocell® 400

- ✓ Filtered chilled
- ✓ Filtered sparkling

Hydrocell® 250

- ✓ Filtered boiling

RODI purification

Upgrading to our patented RODI system delivers a water purity and taste that is second to none, in fact it is purer than every bottled water brand.

Our systems can be installed under the sink alongside the **Hydrocell®** or maybe located remotely in a utility or plant room. RODI systems have the capacity to feed other appliances such as steam ovens, ice makers and coffee machines.

Scale has always posed a major problem for devices that use water. Whilst filtration can reduce the effects of scale, RODI is the only purifier that removes all impurities including scale. Consequently with RODI we can guarantee all our appliances will be free from scale damage.

We believe that RODI water is the healthiest drink on the planet delivering well-being and taste not found in any other source.

ABOVE SINK TECHNICAL

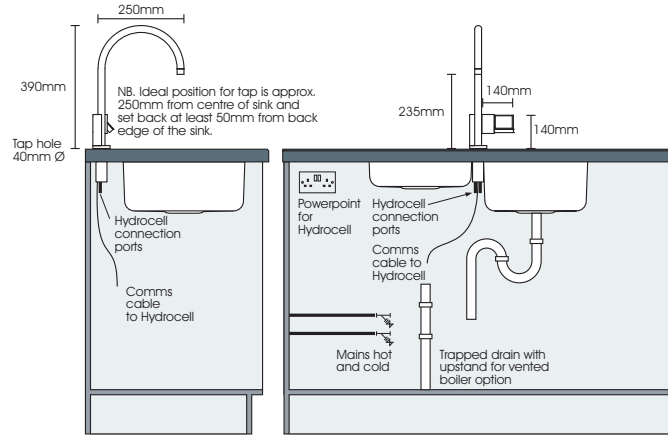

Quatreau™ tap

Quatreau™ is designed, manufactured and assembled in Great Britain from solid stainless steel components.

Finishing is also UK based and available in brushed or polished stainless steel.

Technical details

- 250mm reach
- 140mm wing
- 390mm height

Site preparation

- Tap hole 37-40mm dia.

BELOW SINK TECHNICAL

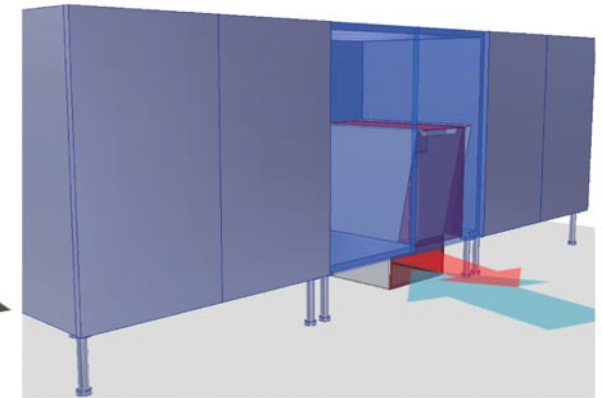
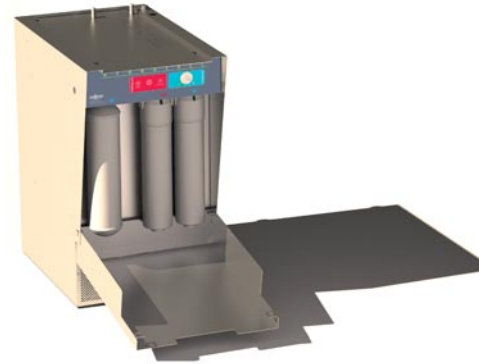

The Hydrocell® subsink system

Hydrocell® is the new compact sub sink system delivering filtered boiling, chilled and sparkling water, on demand, as well as thermostatically controlled mains hot and cold tap water.

- Hydrocell® is fitted with twin multi-media filters that can be changed to suit local water conditions;
- Granular activated carbon (GAC) for removal of chemicals including chlorine, organics, pesticides and herbicides.
 - GAC and scale inhibitor for effective treatment against limescale.
 - Spun polypropylene sediment/particle filtration

Easy to install and easy to replace filters & CO2, Hydrocell® is connected to the mains hot and cold supply and can also take a feed from our patented RODI system.

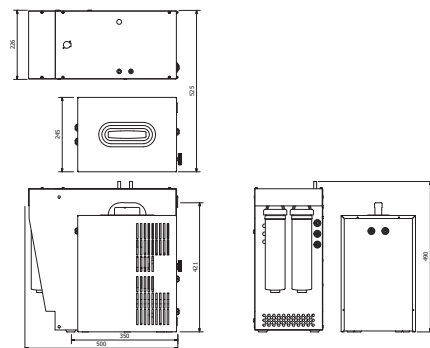
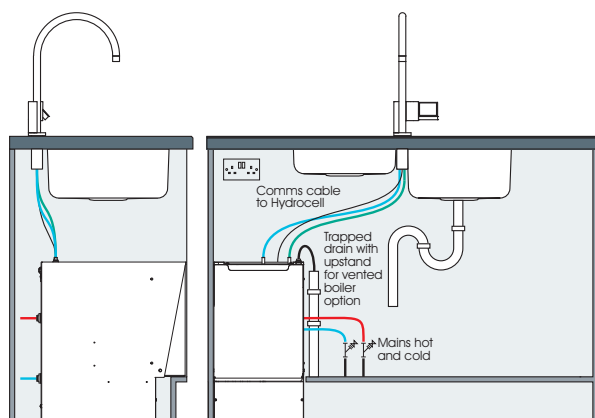

HYDROCELL® 500

- ✓ Thermostatically controlled hot mains water
- ✓ Cold mains water
- ✓ Filtered boiling
- ✓ Filtered chilled
- ✓ Filtered sparkling
- × Filtered ambient

Technical details

- Boiler - 2.4Kw 150 cups per hour
- Chiller - 20ltr per hour below 5°
- Carbonator - 20ltr per hour below 5°
- Stage 1 filter
- Stage 2 filter
- Carbon dioxide module
- Stainless steel construction
- Innovative kickspace ventilation
- 500 (h) x 310 (w) x 500mm (d)

Site preparation

- 315mm section of cupboard base and kick board removed
- Isolated mains hot fitted with Y strainer
- Isolated mains cold fitted with Y strainer
- Trapped drain with upstand
- Powerpoint 13amp

HYDROCELL® 450

- ✓ Thermostatically controlled hot mains water
- ✓ Cold mains water
- ✓ Filtered boiling
- ✓ Filtered chilled
- × Filtered sparkling
- ✓ Filtered ambient

Technical details

- Boiler - 2.4Kw 150 cups per hour
- Chiller - 10ltr per hour at 10° (+/-2°)
- Stage 1 filter
- Stage 2 filter
- Stainless steel construction
- 490 (h) x 226 (w) x 500mm (d)
- Plus chiller
421 (h) x 245 (w) x 350mm (d)

Site preparation

- Hydrocell 250 plus chiller unit
- Isolated mains hot fitted with Y strainer
- Isolated mains cold fitted with Y strainer
- Trapped drain with upstand
- Powerpoint 13amp x 2
- **Must be ventilated**

HYDROCELL® 400

- ✓ Thermostatically controlled hot mains water
- ✓ Cold mains water
- × Filtered boiling
- ✓ Filtered chilled
- ✓ Filtered sparkling
- × Filtered ambient

Technical details

- Chiller - 20ltr per hour below 5°
- Carbonator - 20ltr per hour below 5°
- Stage 1 filter
- Stage 2 filter
- Carbon dioxide module
- Stainless steel construction
- 490 (h) x 226 (w) x 500mm (d)
- Plus chiller/carbonator
421 (h) x 245 (w) x 350mm (d)

Site preparation

- Hydrocell 250 plus chiller/carbonator unit
- Isolated mains hot fitted with Y strainer
- Isolated mains cold fitted with Y strainer
- Trapped drain with upstand
- Powerpoint 13amp x 2
- **Must be ventilated**

HYDROCELL® 250

- ✓ Thermostatically controlled hot mains water
- ✓ Cold mains water
- ✓ Filtered boiling
- × Filtered chilled
- × Filtered sparkling
- ✓ Filtered ambient

Technical details

- Boiler - 2.4Kw 150 cups per hour
- Stage 1 filter
- Stage 2 filter
- Stainless steel construction
- 490 (h) x 226 (w) x 500mm (d)

Site preparation

- Isolated mains hot fitted with Y strainer
- Isolated mains cold fitted with Y strainer
- Trapped drain with upstand
- Powerpoint 13amp

RODI - PURER THAN BOTTLED WATER

Our health has never been more important to us and the purity of the water we drink each day is paramount. Bottled water is not the best option, nor is it pure. One only has to look at the analysis on the bottle label to see the level of impurities.

We supply, install and maintain RODI drinking water systems, the world's most advanced purifiers - taking water back to its natural healthy state. This patented RODI (Reverse Osmosis with De-ionisation) process removes 99.99% of all contaminants found in tap water to produce the purest, and in our opinion, the healthiest drinking water. It is purer than bottled water and with a 95% lower carbon footprint you can feel good about using a product that is environmentally sound.

Making RODI the source of drinking water in your home means an end to the inconvenience of bottled water and its associated waste. Better still, you'll love the taste and will be able to prepare food and cook knowing that there are absolutely no contaminants.

The RODI process removes all hard water scale from tap water thereby protecting your **Quatreau™** and **Hydrocell®** appliances. Boilers in particular are prone to heavy scaling. RODI eliminates this degradation maintaining efficiency and longevity - we guarantee it!

Why RODI?

Removal capacity

Reverse Osmosis is by itself an excellent method for removal of impurities. It has the capacity to remove up to 70% of nitrates, 96% of lead, 98% of heavy metals, 98% of chemicals, 100% disease causing micro-organisms, pathogens and viruses if controlled by an intelligent system.

Our unique process couples RO to DI with intelligent controls, achieving 99.99% purity across the spectrum of impurities, both naturally occurring and man-made.

Lower service costs

The patented RODI process is the only system that incorporates a unique auto-flushing mechanism to remove the build up of plaque from the membrane. This feature helps our membranes to last up to ten times the lifespan of other RO systems. This could mean a saving of over £1000 on membrane replacement over a period of ten years. Ask about our service commitment and free extended warranty.

Consistent 99.99% purity

The patented RODI process is the only system benefitting from integral micro switches for total isolation from mains water when the storage tank is full. It is essential that the RO membrane is separated from mains water pressure when the tank is full. Without this function impurities bleed through to the 'pure' storage. The unique management system used with RODI ensures purity is kept to the highest level possible.

Water efficiency

We are the only company to have achieved such high levels of water efficiency in our domestic systems. Our RO process achieves 2:1 production ratio whilst RODI achieves 3:1.

Other RO systems use basic mechanical valves resulting in lower levels of water efficiency.

Our RODI equipment is unique, utilising high quality micro switches and an intelligent management system that minimises water usage and maximises purity.



Aqualite RODI water system
A purer and environmentally responsible
answer to bottled water

THE PATENTED RODI PROCESS

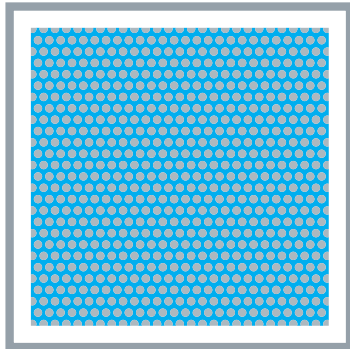

MEMBRANE

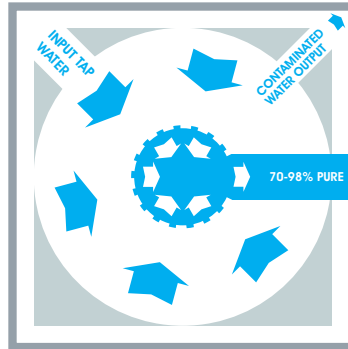

MEMBRANE

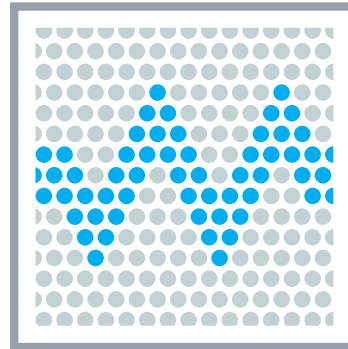

MEMBRANE

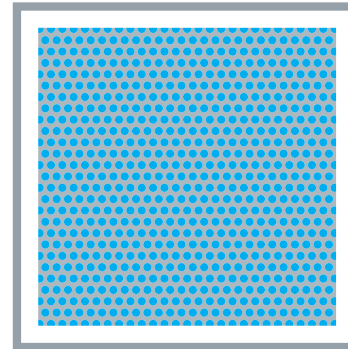

Stage 1

Granular Activated Carbon (GAC)

The Carb12 pre-filter removes chlorine and other organic impurities and serves to protect Stage Two, the Reverse Osmosis membrane, from damage.

GAC is an excellent media for the absorption of chemicals found in raw tap water but has little or no effect on dissolved solids, micro-organisms, heavy metals, pathogens and viruses.

Jug filters and filter taps use small quantities of GAC as the primary process to improve the taste of tap water. GAC is an effective filtration media rather than a purification process.

Stage 2

Reverse Osmosis (RO)

With the chlorine removed, the raw tap water passes into the Reverse Osmosis module. Our own patented thin film composite (TFC) membrane is the only RO with US Environmental Protection Agency (EPA) certification meaning this is the only RO system certified suitable for the removal of micro-organisms from water.

At 0.0001 microns it is capable of removing 100% of disease causing micro-organisms and up to 98% of inorganics and 70% of nitrates.

Our patented flushing mechanism removes scale and biofilm extending membrane life to up to ten years.

Stage 3

De-ionisation (DI)

Another unique and essential feature of our patented system is the de-ionisation module. The impurities that breach RO can only be removed by DI. This stage is an ion exchange process removing heavy metals, nitrates¹, gases, volatile organic chemicals² and oestrogens, replacing them with hydroxide (OH) or hydrogen (H), better known to us as H₂O. The result is PureH₂O, the purest water available.

¹ Nitrates have a habit of mimicking oestrogen and starving the red blood cells of oxygen. They should be removed from drinking water.

² Nitrates and volatile organic chemicals hide the hydrogen bond of the water molecule that makes them invisible, thus, passing through RO but not DI stages.

Stage 4

Granular Activated Carbon (GAC)

The final stage, a post-filter 'polishing' process, ensures any residual gases are removed producing a great taste.



RODI WATER TECHNICAL

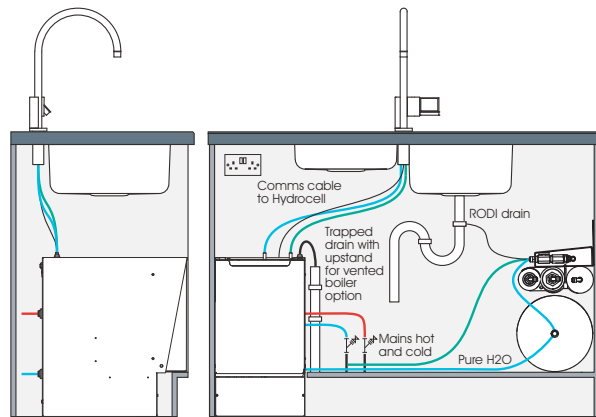

Aqualite™ RODI Purification System

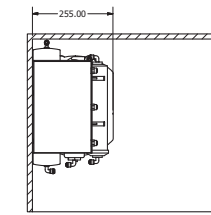
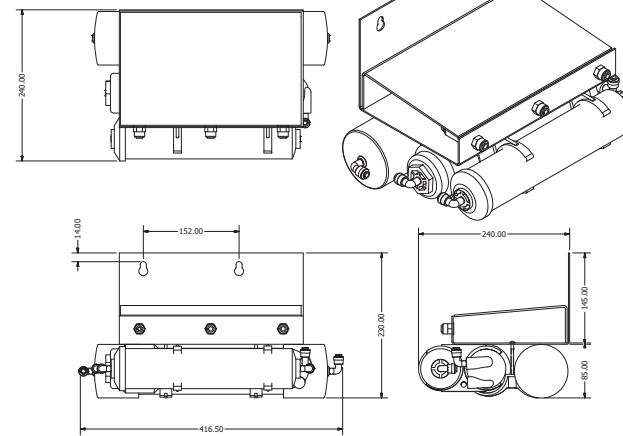

SECTION B-B

Typical installation for subsink systems with standard 8ltr reservoir

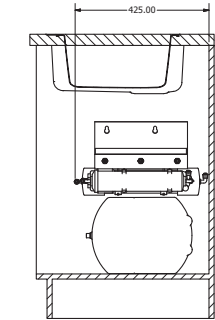
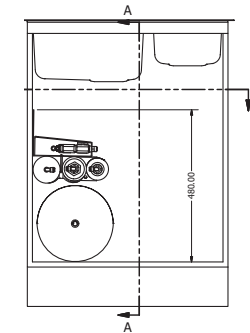

SECTION A-A

RODI water purification system

Our most advanced RODI system and technologically the world's leading drinking water system. With its rapid fill system the Aqualite can be connected to other kitchen appliances including steam ovens, fridges, ice makers, coffee machines and our **Quatreau™** touch-sensitive tap system. The RODI system will help ensure your appliances never scale up and ice will be crystal clear with no cloud or sediment.

RODI PURIFICATION DATA

Removal rates

- 99.99% micro-organisms
- 99.99% organics
- 99.99% heavy metals
- 99.99% lead
- 99.99% nitrates

Patented micro switch deactivation

The only RO system that accurately deactivates and reactivates in line with optimum tank pressure resulting in higher levels of purity and consistent production rates.

Patented anti-bleed mechanism

Effectively minimises impurities breaching the RO stage.

Site preparation

- Isolated mains cold (15mm)
- Trapped drain with upstand or connection can be made to trapped drain on sink
- Powerpoint 13amp

Patented autoflush

For prolonged membrane life ten years longer than standard RO systems.

Patented coupling of DI to RO

DI effectively removes nitrates, VOCs, gases and other impurities that RO cannot effectively remove.

WHAT OUR CUSTOMERS SAY

"I had heard that the finest drinking water one could get in their own home, was from the PureH2O Company, through a RODI Purification System and that it had been around for quite a while - with loyal and devoted customers refusing for many years to drink anything else! I wanted this in my home of course, as buying and storing mineral waters, or having to filter tap water through plastic containers, just wasn't appealing to me anymore, especially when I realised that they weren't so pure and great anyway!

Then I researched that such great water can not only come boiled and chilled but also carbonated, which for a devout fizzy water drinker like myself, was fantastic news - even less bottles and canned drinks to have to store, and no more kettle! I found out all this after searching the website for, in my opinion now, the best tap in the world - as an interior designer keen on innovation, it was only a matter of time before I found **Quatreau™** Taps. All that great water in its different forms, coming out of one stylish tap? Very modern, very innovative, very cool.

The rest is history, I own one, it always works great, the water is delicious and I will be taking everything with me if I ever leave."

Nicholas Spencer

Interior Designer

www.nicholas-spencer.com

"We installed the **Quatreau™** tap system in our new kitchen and I have to say that the additional functions of boiling sparkling and chilled have made a remarkable difference in the way we use the kitchen. We chose to install **Quatreau™** with the RODI water purification system so that we could avoid bottled water. Both tea and coffee look so much better when made with pure boiling water and there is no unsightly scum or film on top of the drinks anymore. Tea steeps perfectly with an amber colour we never saw when using tap water whilst the coffee tastes stronger and cleaner.

The grandchildren love making drinks with the chilled and sparkling water using organic cordials or fruit and we know it's much healthier than the fizzy drinks we no longer buy (saving us money). You only need half the amount of cordial to get a good flavour - PureH2O tell me this is because the RODI system removes all the impurities that prevent the full flavours coming out when we used tap water. I can honestly say that our **Quatreau™** has exceeded our expectations. It brings a whole experience and convenience to the kitchen and is now the most used appliance we have plus we no longer buy bottled water or fizzy drinks."

Tony Buckley

Buckinghamshire

"It really appeals to my inner gadget lover. I saw lots of different designs but this one incorporates the mains water, as well as pure filtered drinking water, boiling and carbonated all from the same spout. It's controlled with a full colour LED touch screen panel that's very 21st Century."

Paul Stratton

Surrey



quatreau™

Exclusively from The PureH2O Company
World leading water purification
30 years pure excellence

Unit 21 Boundary Business Centre
Boundary Lane, Woking, Surrey GU21 5DH

01483 617000

quatreau.com